



Thank you for selecting EarthWay for your spreader needs. Our production team in Northern Indiana takes pride in building this spreader. Our customer support team is standing ready to ensure your success. Please contact us at www.EarthWay.com to see our full line of commercial, lawn & garden tools.

M20 ELECTRIC SPREADERS



- Always wear protective clothing, eye wear, and dust mask to prevent contact with chemicals and other materials being applied with this machine.
- Remove any material in the hopper before lifting or detaching this machine from the vehicle.
- Care must be taken when lifting this machine so as not to cause personal injury or equipment damage. Never attempt to install this machine to the vehicle alone. Recruit the help of someone to assist when attaching and detaching this machine from the vehicle.
- Refer to the material packaging or the Material Safety Data Sheet for precautionary measures required when handling materials to be applied.

Before attaching this machine, consideration must be given to the load capacity of the vehicle. Refer to the owner's manual of the vehicle for rated load capacity. Be sure to take into account the weight of this machine is 20lbs. and the weight of the material to be placed in the hopper when calculating the total load.

Assembly Instructions:

STEP 1: Unpack all parts from shipping carton to ensure no parts are missing. Refer to the exploded view.

STEP 2: Install the four (#9) 7/8" Tube plugs onto the ends of the two (#15) Frames with the help of a hammer or some other tool.

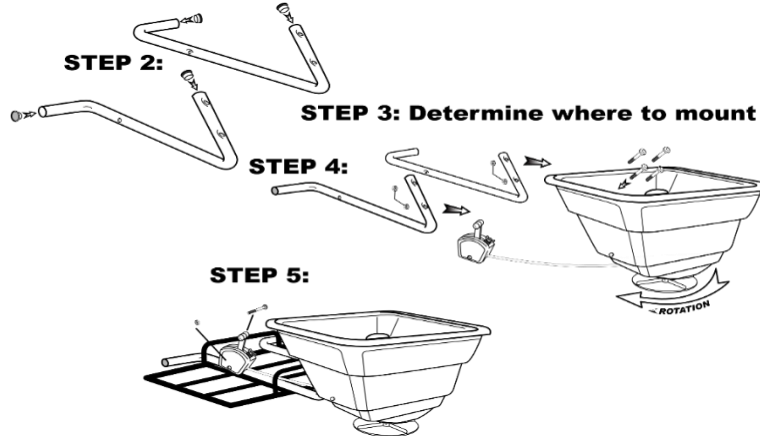

STEP 3: Determine whether to mount on the front or the back of the luggage rack. Depending on whether the M20 is mounted to the front or rear rack, you will need to install (#4) Control assembly to either the right (#11) or left (#15) Frame tube to allow for use with the non-throttle hand. Wait until the unit is mounted to the Quad before installing the Control.

STEP 4: Next install four 1/4-20 x 1-1/2" Carriage bolts (#12) through the Hopper assembly and then through ONE of either side Frame and secure with 1/4-20 Hex Nut (#8).

STEP 5: Now position the M20 to the Quad and install the remaining Frame member as outline above in **STEP 4**. Now install the Control assembly (#4) to the Frame and secure with a 1/4-20 x 1-3/4" Carriage bolt (#13) and 1/4-20 Hex Nut (#8) and tighten firmly to allow movement, but not allow the lever to move unassisted.

Now install the M20 on your quad as outlined on the following page.



WARNING

KEEP HANDS AWAY FROM ANY SPINNING OBJECT, SHUT-OFF PLATE, SHUT-OFF MECHANISM LINKAGE, AND THE INSIDE OF THE HOPPER, EXTREME INJURY CAN OCCUR.

HOW TO OPERATE SAFELY:

- Read, understand, and follow all product label information provided on the material being applied.
- An adjustable solid stop is provided that allows the operator to adjust to the desired opening position on the rate setting control prior to operation of the vehicle. This allows repeatability to the stop without the need to look at the control while operating the vehicle.
- Establish the correct rate and then lock the stop in that position using the thumb wing nut on the setting control.

OPERATING INSTRUCTIONS:

Before filling hopper, become familiar with the operation of this spreader. (Practice the following steps)

- Turn the motor switch to the ON POSITION, so that the impeller is turning before going on to the next step.
- While driving forward pull the lever back to the stop, this opens the shut off plate on the spreader.
- To stop the flow of material, Push the lever to "0" or closed position, then turn the motor off when finished.
- When finished empty any remaining material from hopper.
- Thoroughly wash spreader and allow to dry before storing. A light coating of oil will help prevent corrosion of all metal surfaces.

MOUNTING INSTRUCTIONS:

Position the M20 on the vehicle so that the impeller is positioned to be able to spin clear of any part of the vehicle, this will allow a full 180 degree spread pattern. Secure the frame to the mounting location with the enclosed J-Bolts at positions that will secure the spreader so that it will not move when operating the vehicle. For best results mount the spreader so that the impeller is as close to the vehicle as possible, but clears any parts on the vehicle and place the J-Bolts as shown below.

Connect the black wire (ground) to the negative (-) post on the battery and the fused wire to the positive (+) post on the battery.



If for any reason the impeller rotates counter clockwise, reverse the battery connection of the spreader. Correct rotation is clockwise.

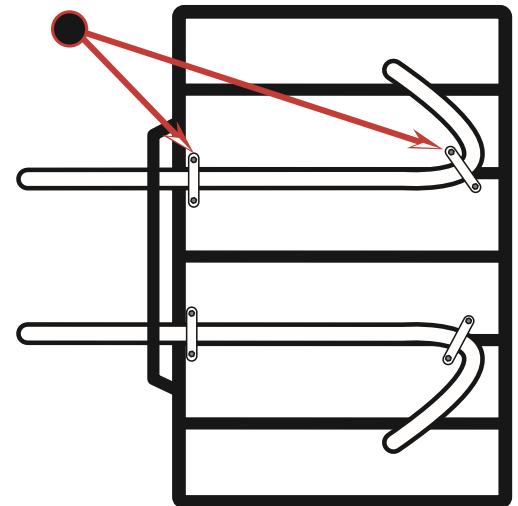

SPREADER CALIBRATION INSTRUCTIONS:

- Loosen stop on the gauge and set to #30
- Open the lever to #30 and make sure that the shut-off is fully open
- Loosen the cable clamp on the bottom of the hopper and slide the outer cable IN/Out until the shut-off is fully OPEN. Tighten the cable clamp and retest.
- Calibration is now complete

TO CALCULATE THE SETTING:

- Determine how much material is to be applied per 1,000 sq/ft.
- Measure off a distance of **50 feet**, preferably on a paved surface such as a parking lot.
- Weigh out enough of the material to be applied to fill the hopper at least half full. Record the weight for future use.
- With the unit mounted on the vehicle and the hopper at least half full of the material to be spread, position the vehicle far enough before the beginning of the 50 foot test area so that the vehicle will achieve the desired speed before you reach the starting line.

- Set the rate setting stop at a position that you feel would be an appropriate setting.
- Start the vehicle in motion and as you cross the starting line (of the 50 feet) move the rate lever to the open position against the stop. Take care to be aware of what is going on around you maintaining control of the vehicle.
- Continue from the starting line with the unit spreading the material. As you cross the finish line move the rate lever to the closed position.
- Stop the vehicle and note the width of the spread path that was just completed.
- Return to the start point and empty the remaining material from the hopper into your weighing container and re-weigh.

All spare parts listed herein may be ordered direct from the manufacturer. Be sure to give the following information when ordering.

1. Model Number
2. Part Number
3. Part Description

You can contact us by calling (574) 848-7491 to place an order with a credit card, or purchase online at www.Earthway.com. Questions? Email us at sales@earthway.com

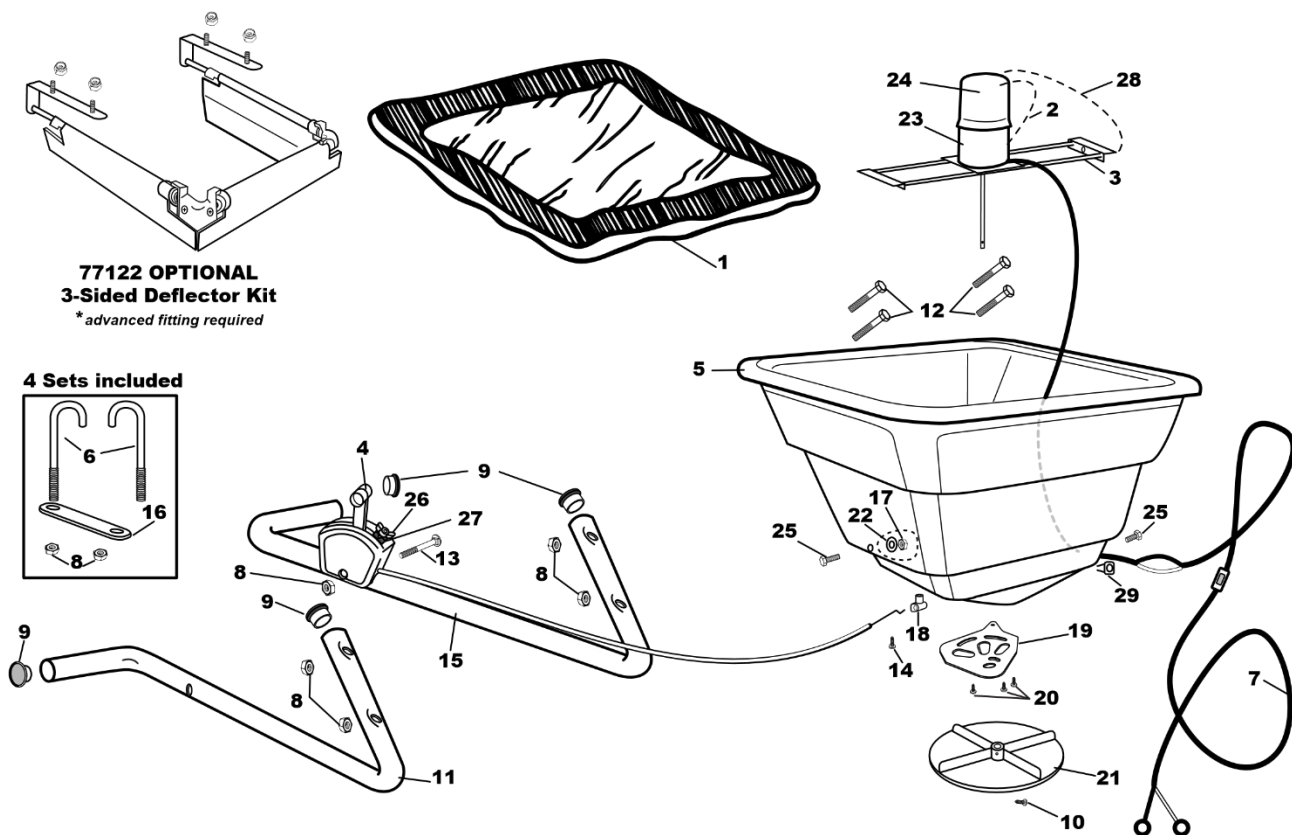

M20 Parts List					
Key #	Part #	Description	Key #	Part #	Description
1	77003	HEAVY DUTY RAIN COVER	16	43050	U-BOLT STRAP (M20)
2	77101	ELECTRIC MOTOR DRILLED (M20)	17	32103	1/4-20 NYLON INS LOCKNUT ZINC
3	60323	MOTOR SUPPORT ASSEMBLY (M20)	18	12318	LOWER HOUSING CLIP
4	60523	CONTROL ASSEMBLY-M20 REV907	19	12221	SHUT OFF PLATE
5	60322	HOPPER ASSEMBLY (M20)	20	31138	#8 X 3/8" PMT #8 HD COARSE BLACK
6	44287	"J" BOLT (M30/M20)	21	12109	IMPELLER (9" DIA)
7	60511	WIRE HARNESS ASSEMBLY (M20/M30)	22	34108	9/16" OD. X .257 ID. WASHER ZINC
8	32100	1/4-20 HEX NUT ZINC	23	12309	MOTOR BASE (M20/M21)
9	19132	7/8" TUBE PLUG	24	12310	MOTOR CAP (M20)
10	31103	#6 X 1/2" TYPE 25 HWHS ZINC	25	31101	1/4-20 X 3/4" HHMS ZINC
11	25118	FRAME (M20) REV 907 RIGHT	26	32106	10-24 WING NUT ZINC
12	37101	1/4-20 X 1 1/2" CARRIAGE BLT Z	27	12222	INDICATOR-BROADCAST
13	37108	1/4-20 X 1 3/4" CARRIAGE BOLT ZINC	28	60422	MOTOR ASSEMBLY (M20)
14	31124	#10 X 5/8" TYPE A PHPS ZINC	29	77032	STRAIN RELIEF (#1184) HEYCO
15	25119	FRAME (M20) REV 907 LEFT			

Installation the **77122 3-Sided Deflector Kit** requires drilling of the hopper and motor support assembly for fitting.



EC DECLARATION OF CONFORMITY

(Machinery Directive & Electromagnetic Compatibility Directives)

Herewith we declare that the machinery described below is in accordance with the relevant health and safety requirements of the EC Council Directives concerned with Machinery and Electromagnetic Compatibility. No alterations are to be made to the machine without prior consultation and approval of Earthway Products, Inc. otherwise the Declaration may become invalid. This equipment must be commissioned, used and maintained strictly in accordance with the operating and maintenance instructions issued with the machine. Operators must be trained in accordance with the recommendations given in the operating and maintenance instructions issued with the machine.

Description of Machine: **EarthWay® M20 12-volt Broadcast Spreader**

Date of Supply: AS INVOICED DATE

Relevant EC Council Directives:

Machine Directives 89/392/EEC and subsequent amendments.

Electromagnetic compatibility Directive 89/336/EEC and subsequent amendments.

DO NOT RETURN TO DEALER FOR REPAIR

CUSTOMER SERVICE

574.848.7491 | SUPPORT@EARTHWAY.COM | www.EARTHWAY.com | 1009 Maple Street, Bristol, IN 46507

ONE YEAR WARRANTY

EarthWay Products, Inc. warrants this product free of defects in original workmanship and materials for a period of one year to the end user with the original purchase receipt. If a manufacturing non-conformance is found, EarthWay Products, Inc. at its discretion will repair or replace the part(s)/product at no charge provided the failure is not the result of incorrect installation, mishandling, misuse, tampering, or normal wear and tear as determined by EarthWay.

EarthWay at its discretion may require that the part(s) or product be returned along with the original purchase receipt for examination and compliance with the terms of this warranty. Do not return any product without first receiving authorization from EarthWay Products, Inc.

To seek remedy under this warranty, contact EarthWay Products, Inc. at 574-848-7491, support@earthway.com or write to EarthWay Products, Inc. 1009 Maple Street, Bristol, IN 46507 and describe the nature of the manufacturing defect. **SPECIFIC LIMITATIONS:** This warranty covers only the part(s) or product; any labor charges associated with repair or replacement of non-conformances are specifically excluded. Due to the corrosive nature of most fertilizers and ice melt products, EarthWay Products, Inc. makes no warranty against and specifically excludes part(s) or product degradation or failure due to corrosion or its effects.